

















































- 12x  1
- 6x  2
- 6x  3
- 3x  4
- 4x  5
- 2x  6
- 2x  7
- 2x  8
- 2x  9
- 2x  10
- 1x  4
- 1x  6
- 5x  10
- 1x  25
- 27x  3
- 32x  3
- 28x  3
- 19x  3
- 8x  3
- 1x  3
- 2x 
- 2x 
- 2x  1
- 4x  2
- 2x  3
- 2x  4
- 3x  5
- 2x  6
- 2x  10
- 1x  0
- 5x  1
- 10x  2
- 7x  3
- 2x  5
- 1x  4
- 3x  3
- 3x  3
- 3x  3
- 6x  3
- 1x  3
- 16x  3
- 20x  3
- 2x  30mm
- 1x  40mm
- 5x  60mm
- 1x  80mm
- 1x  100mm
- 1x  160mm
- 3x  195mm





4

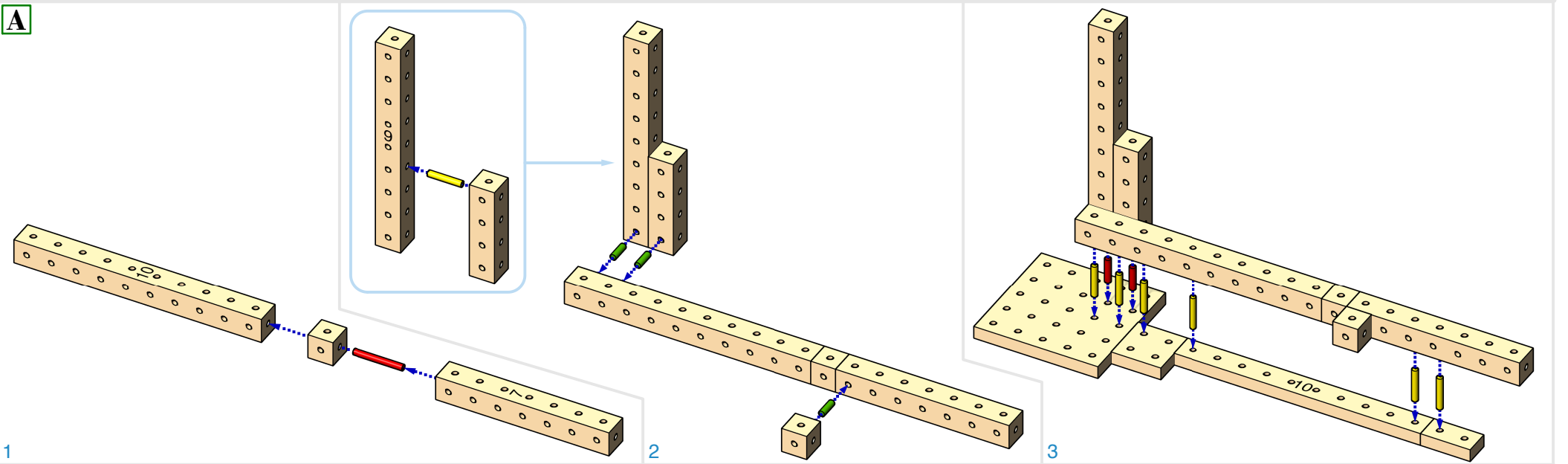
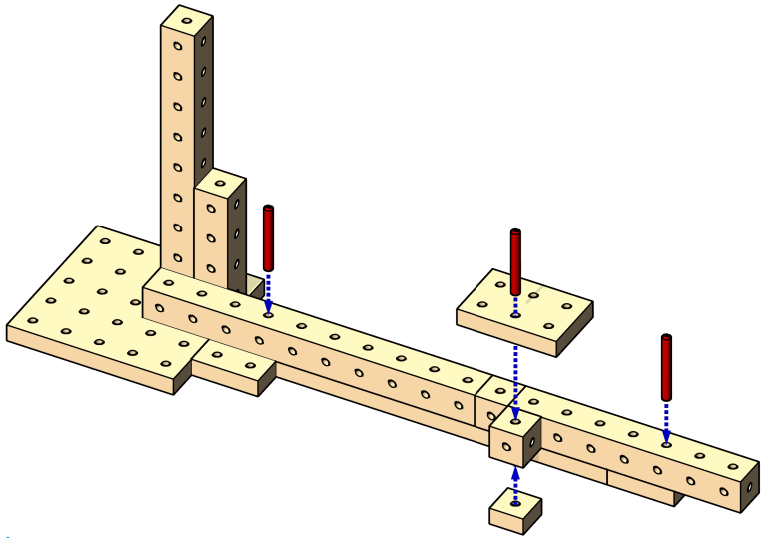
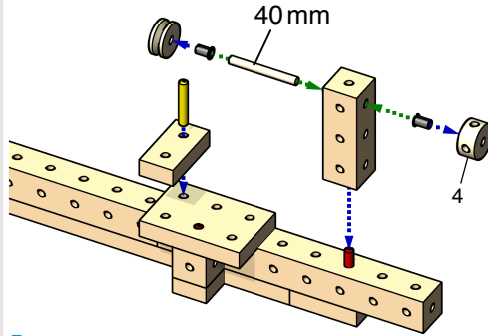

5

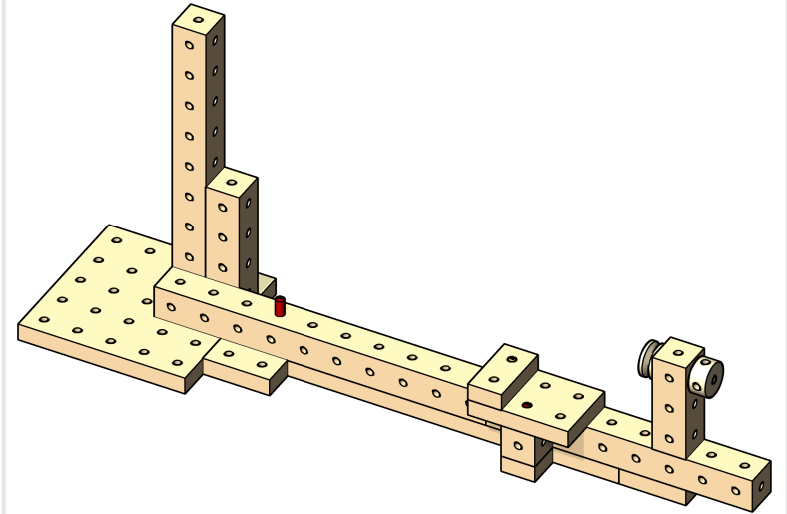

6

A

B

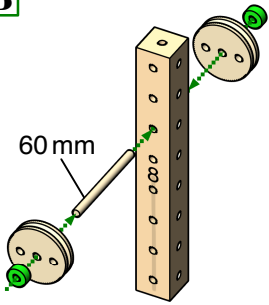

7

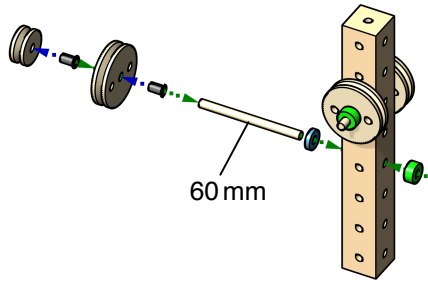

8

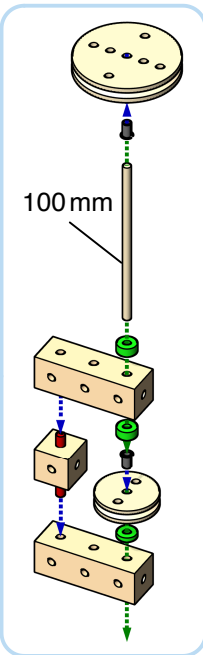

9

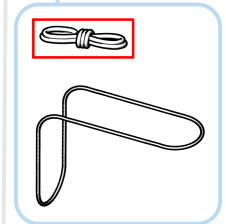
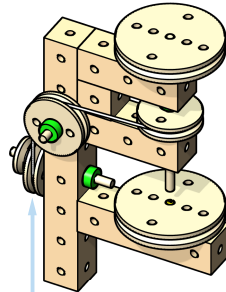

10

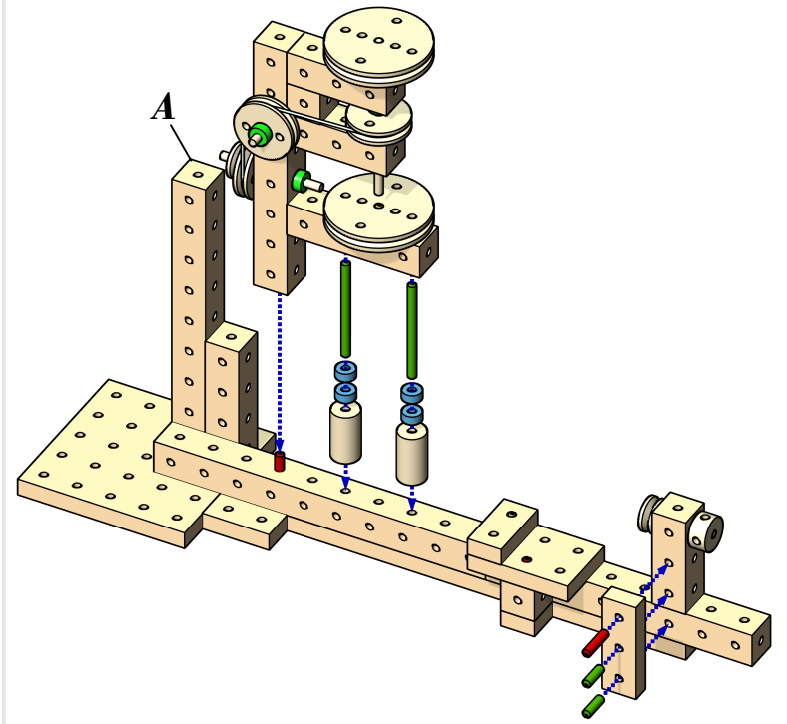

11

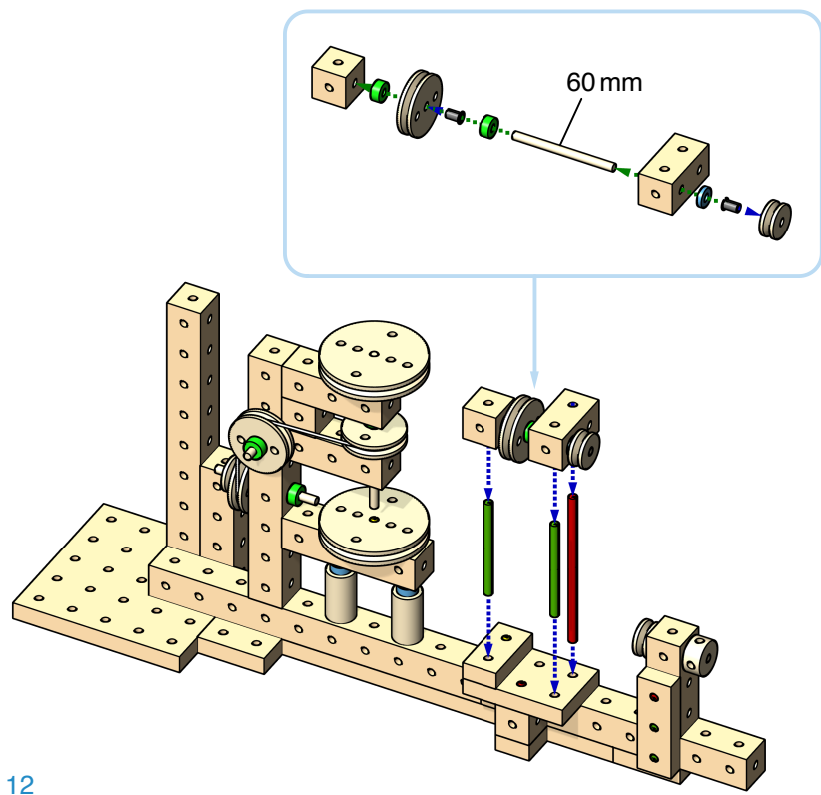

12

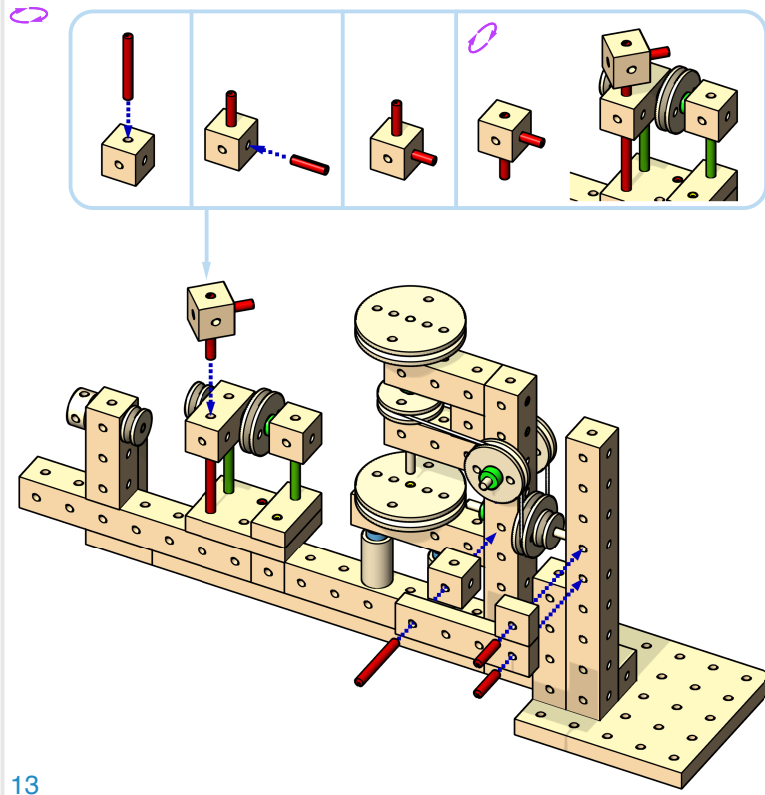

13

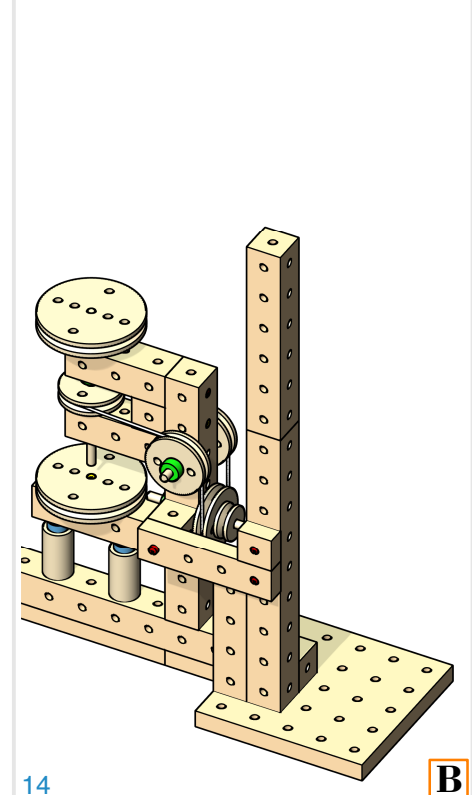

14

B

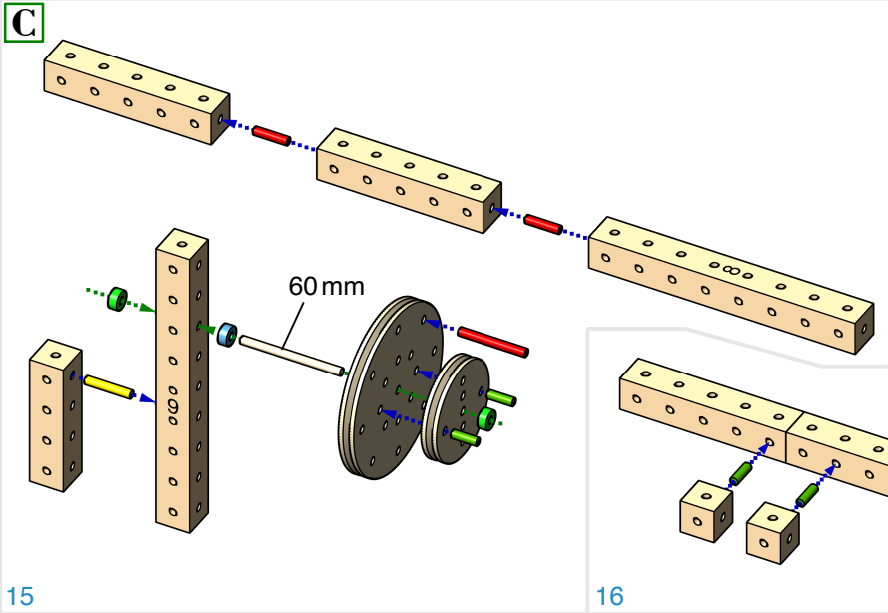

15

C

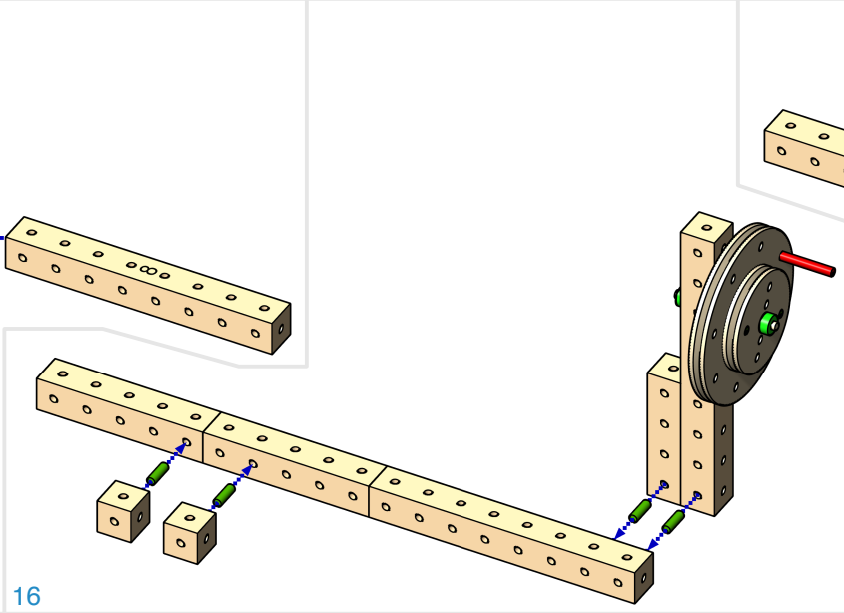

16

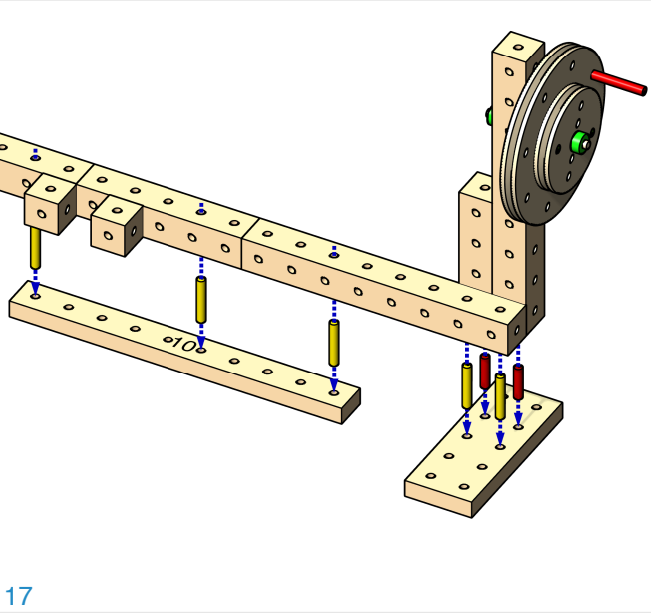

17

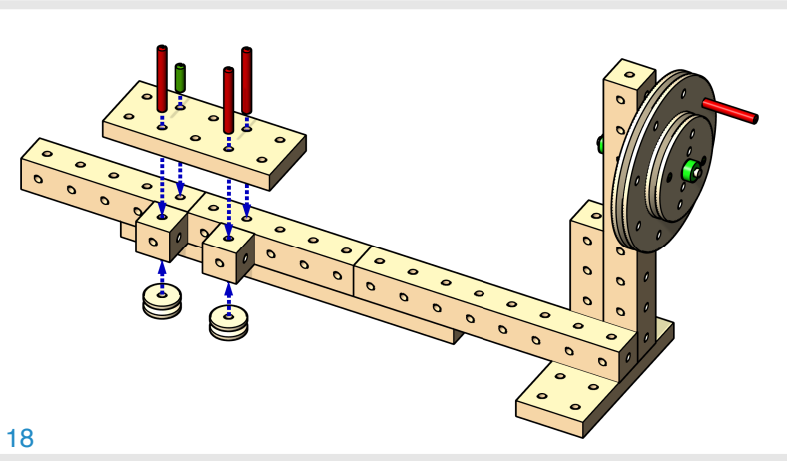

18

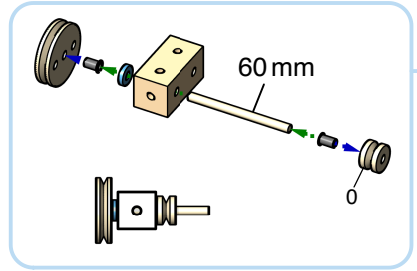

19

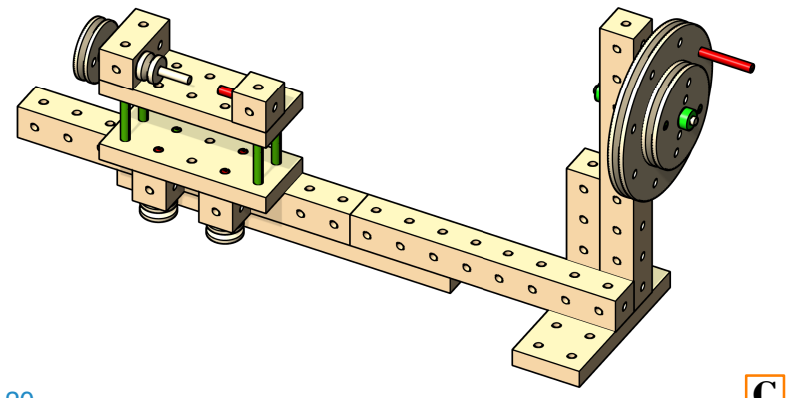
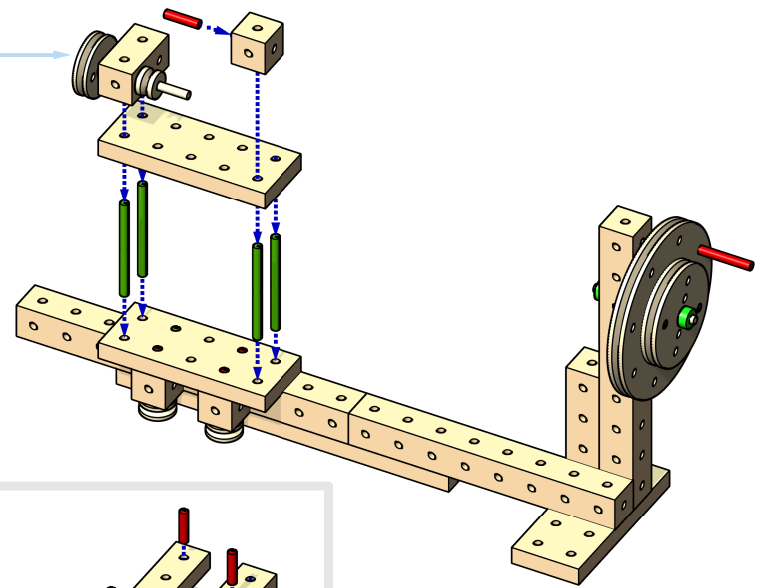

20

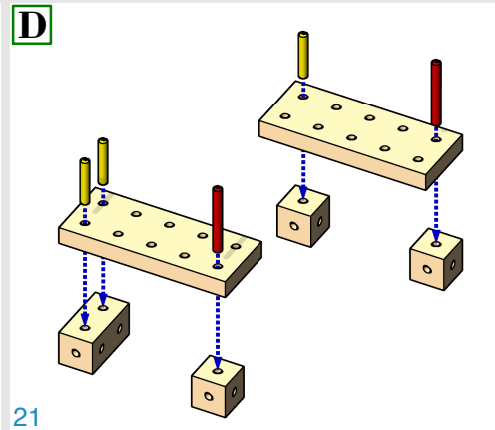

21

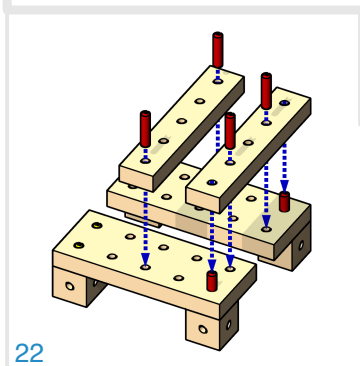

22

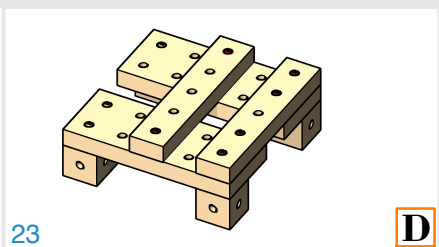

23

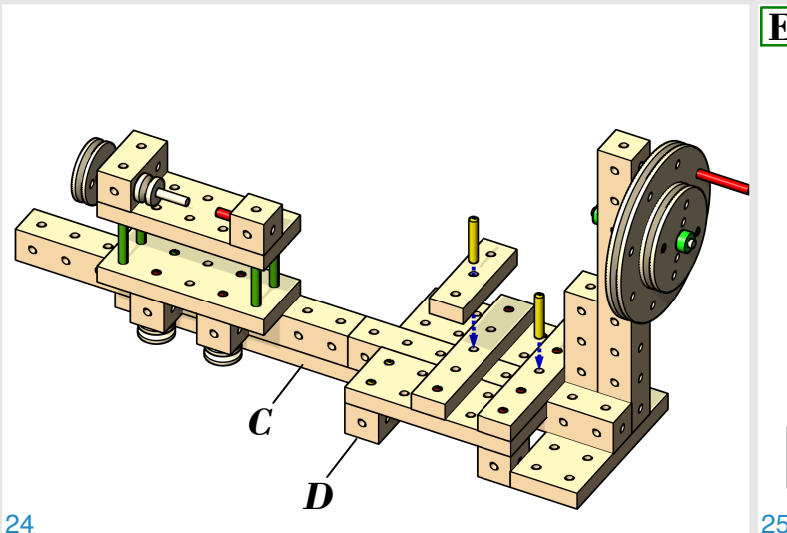

24

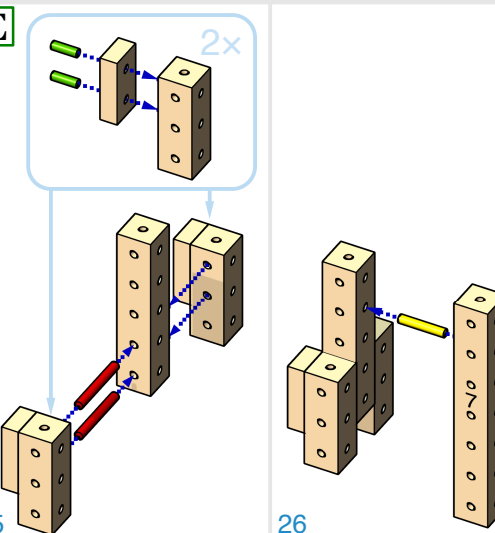

25

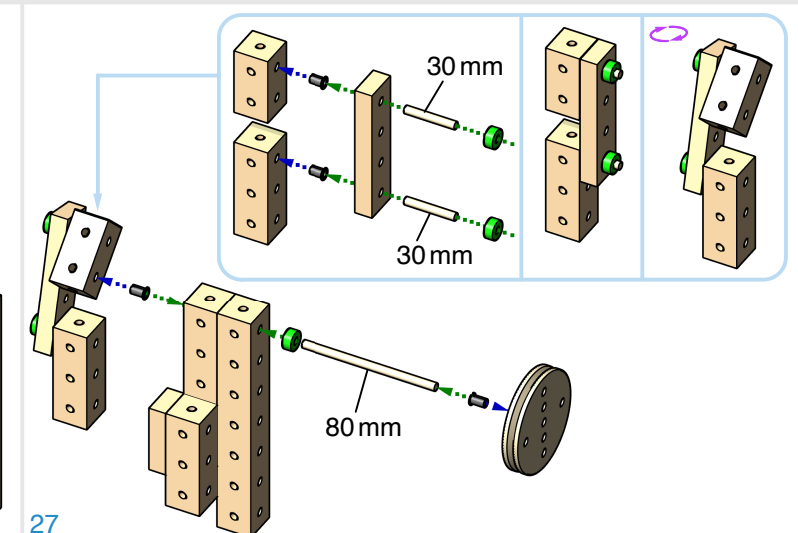

27

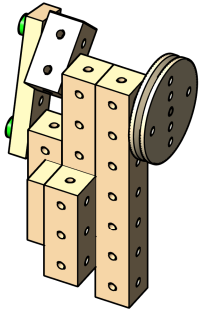

28

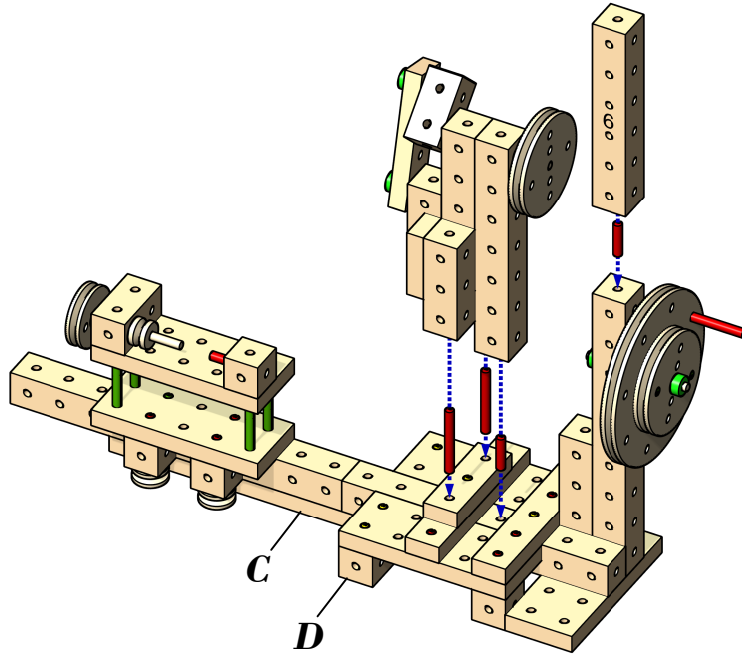
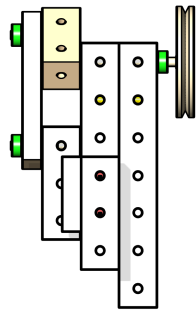

29

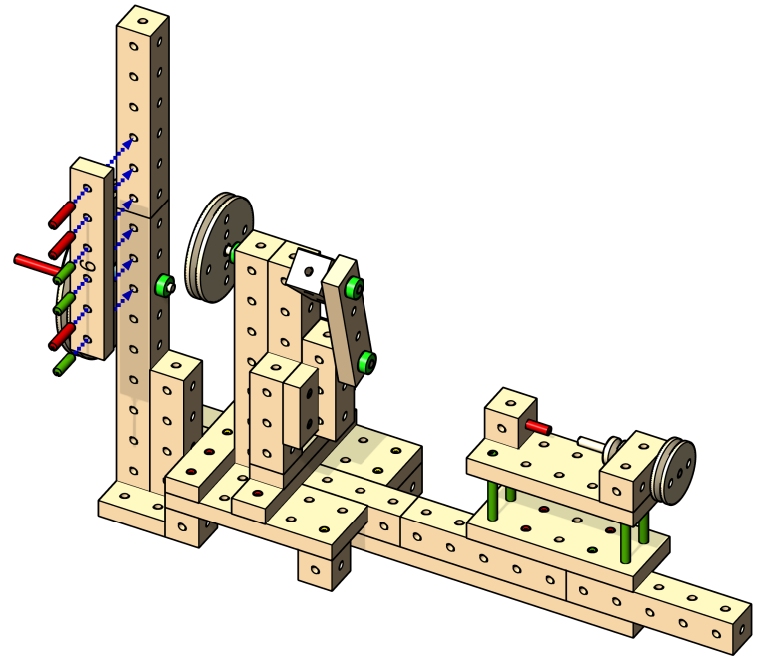

30

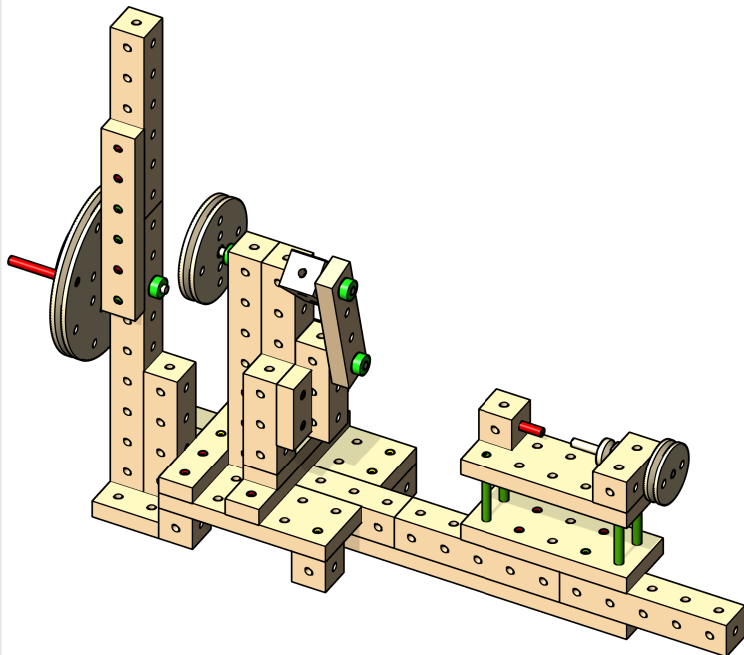

31

F

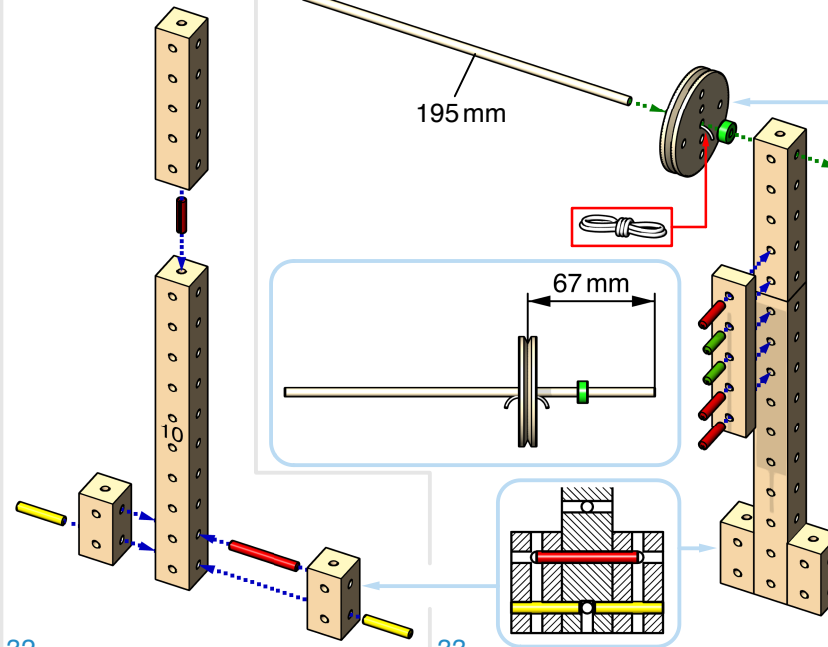

E

32

33

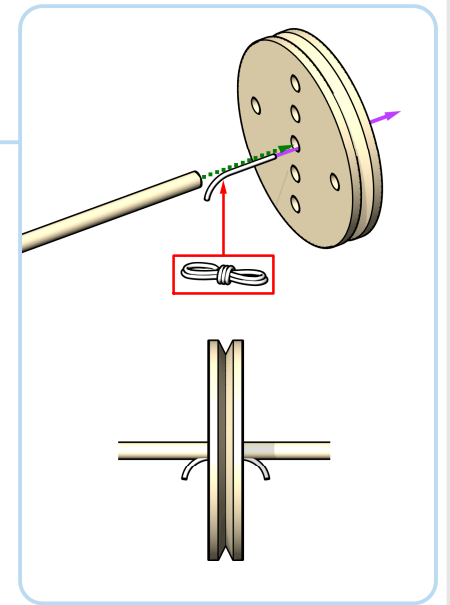
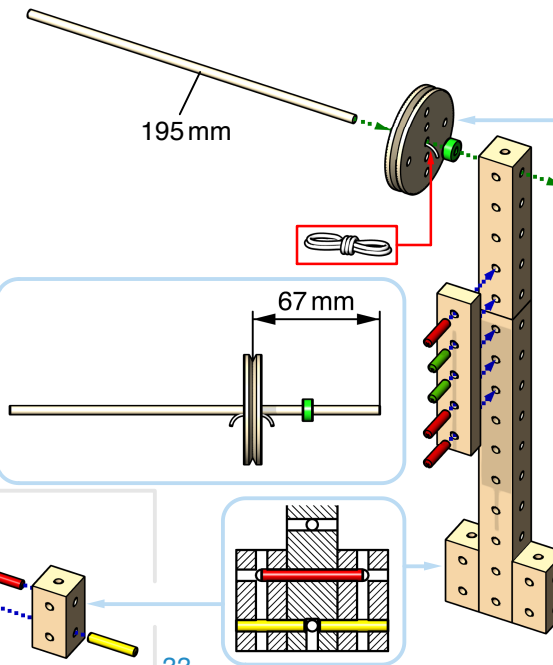

F

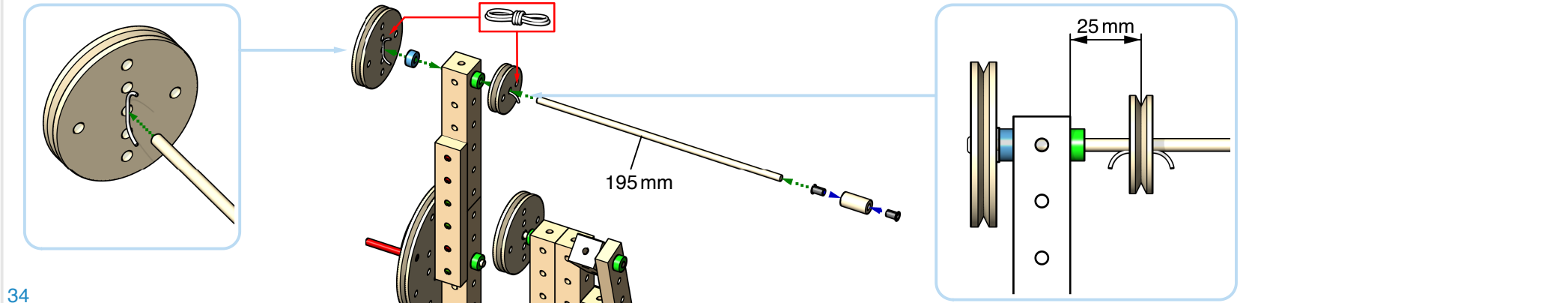

34

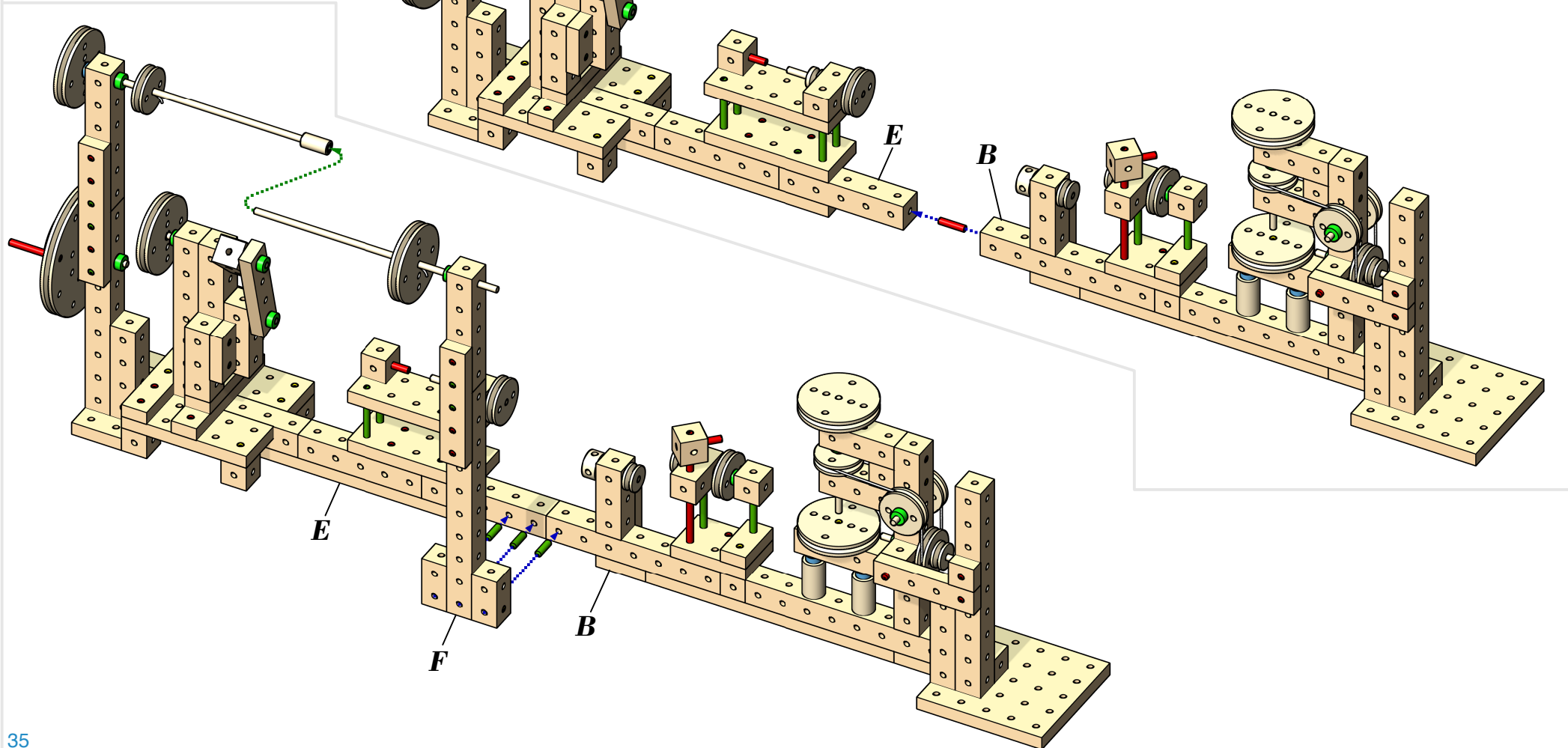

35

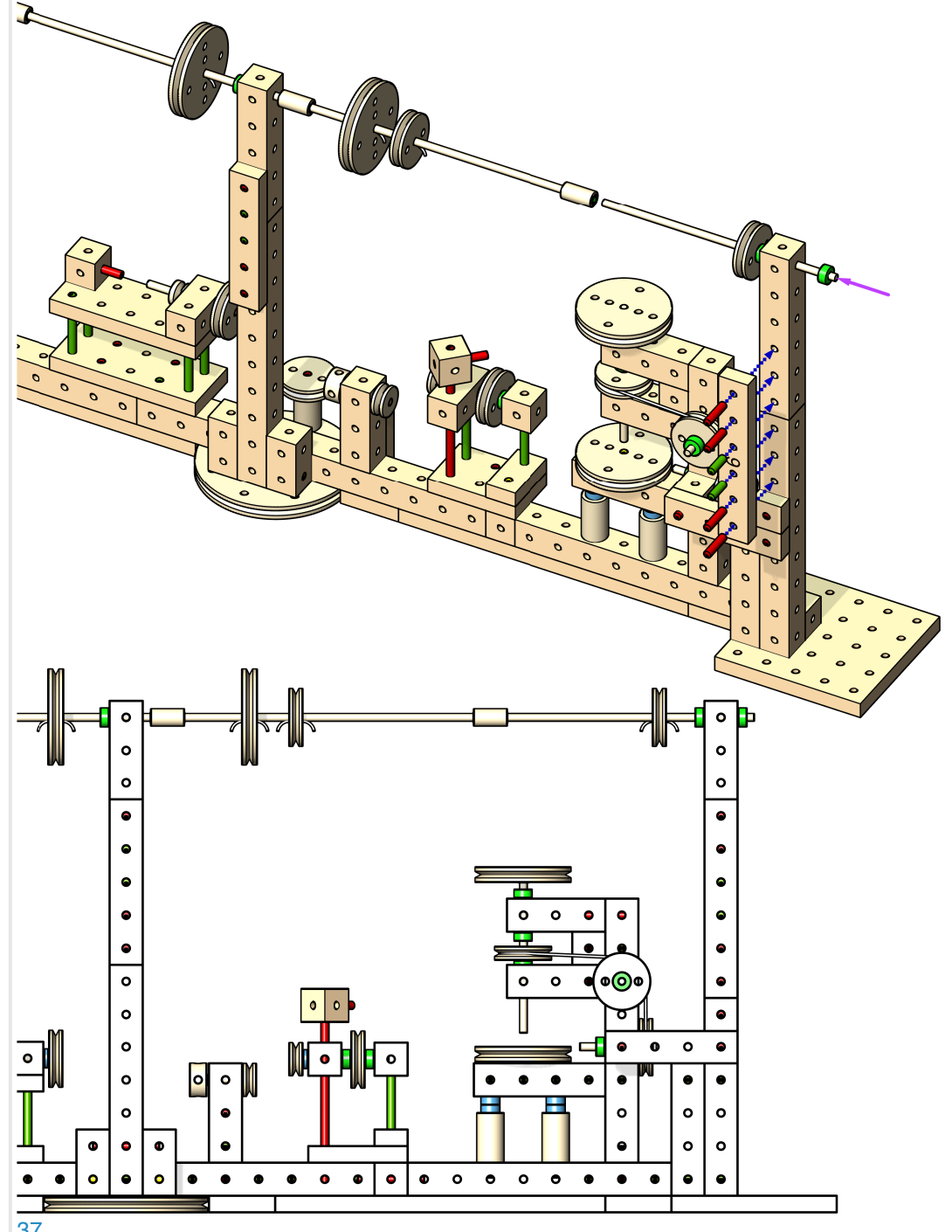
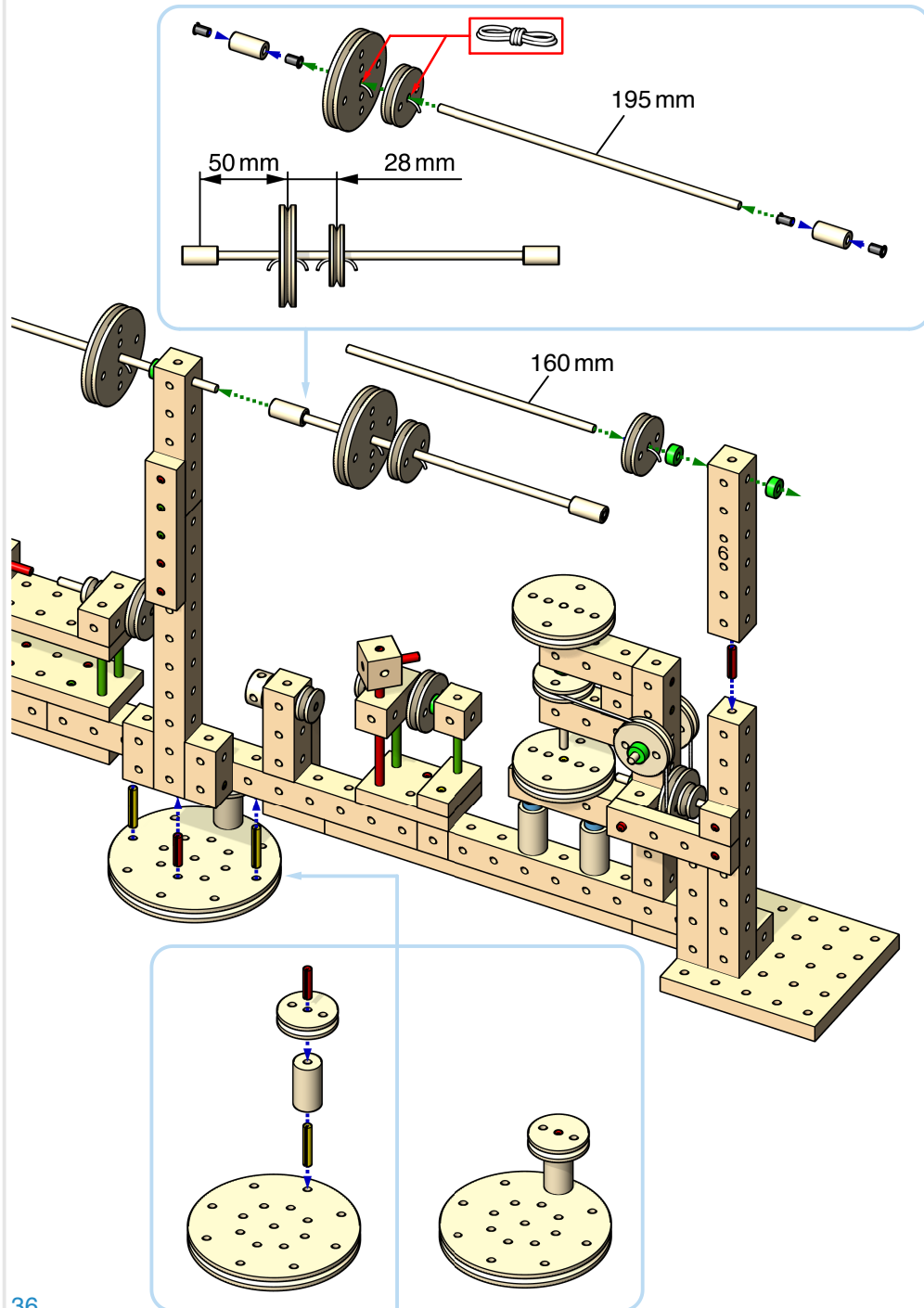

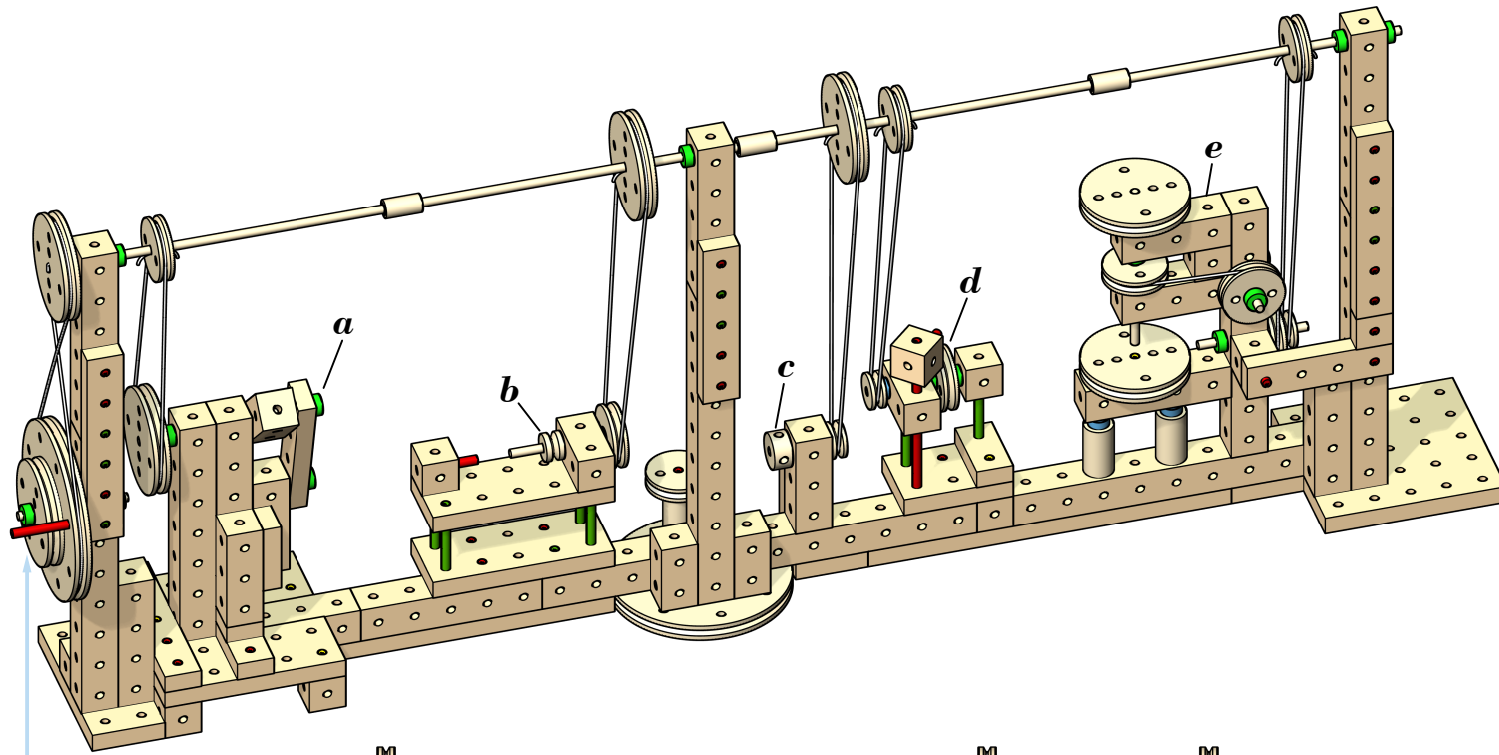
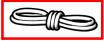

- a** Presse oder Stanze
Press or punching machine
- b** Drehbank
Lathe
- c** Polierscheibe
Polishing wheel
- d** Schleifstein
Grinder
- e** Ständerbohrmaschine
Vertical drill press

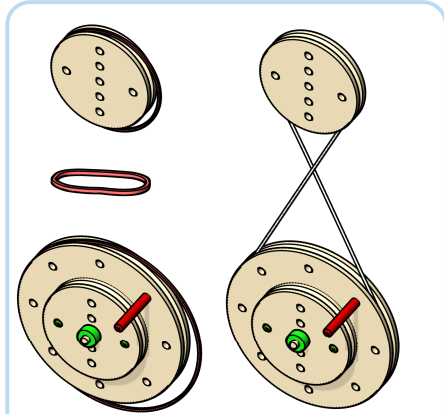

Gummiringe zum Erhöhen der Reibung.
Rubber rings to increase friction.

